

ZONE 1

EFi50xx/EFi120xx/EFi150xx

16"/40 cm

Blower/Exhauster

The electric powered EFixx Series hazardous location blowers/exhausters, with **whole-unit certification**, are intended for use in Adverse Atmospheres in accordance with the limitations of the rating. The whole-unit certification not only provides protection and peace of mind to the user; it also prevents suppliers from being linked to the chain of liability.

The largest hazardous location blowers for highest volume of air movement. Use the EFi50xx (0.5 Hp) when you need a high volume, low velocity, somewhat gentler flow; or the EFi150xx (1.5 Hp) model for higher velocities, increased volumes and reduced purge or cooling times. 16" (40 cm) integrated duct adapters. Stackable in storage or during operation.

Specifications

| Model | EFi50xx (115V/230V) | | EFi120xx (110V/240V) | | EFi150xx (115V/230V) | |
|-----------------------|--------------------------------------|-------------------------------|------------------------------------|---------------------------|---------------------------|-------------------------------|
| Part # | EA8000XX Ships as 115V | EA8000XX-230 Ships as 230V | EA8120XX-110 Ships as 110V | EA8120XX Ships as 240V | EG8200XX Ships as 115V | EG8200XX-230 Ships as 230V |
| IMPA Code | | | | | 591507 | |
| Motor | 0.5 Hp / 0.37 kW | | 1.2 Hp / 0.9 kW | | 1.5 Hp / 1.1 kW | |
| Motor Type | Totally Encapsulated Air Flame Proof | | | | | |
| Electric | 115/230V, 50/60Hz, 1ø | | 110/230V, 50Hz, 1ø | | 115/230V, 50/60 Hz, 1ø | |
| Amps (Start/Run) | 25A / 6A | 13A / 3A | 54A / 10A | 27A / 5A | 80A / 15A | 40A / 8A |
| Cable Lengths | 30'/9m, 14AWG/2.5mm ² | | 25'/7.6m, 14AWG/2.5mm ² | | | |
| Plug Types | Not Included | | A.T.X. 100/130V | A.T.X. 240V | A.T.X. 100/130V | A.T.X. 240V |
| Operating Temperature | -22°F to +104°F / -30°C, to +40°C | | | | | |
| Noise | 90.2 dB @ 3' (1 m) | | 86.1 dB @ 3' (1 m) | | 90.2 dB @ 3' (1 m) | |
| Weight | 49 lbs / 22 kg | | 55 lbs / 25 kg | | 61 lbs / 28 kg | |
| Dimensions (h/w/d) | 19 x 18 x 16 in / 48 x 46 x 41 cm | | | | | |
| Impeller | 21-Blade | | 7-Blade | | | |

IP55 rain tested switch enclosure

Durable, PC/ABS Anti-static casing is weatherproof, flame retardant and chemical resistant



* EFi50xx has 21 blades

«Certifications & Approvals

Certification String: II 2 G EX de IIB T6 Gb

IECEx UL Certificate #: **13.0062X**

EC-Type Examination Certificate #: **DEMKO 09 ATEX 0926969X**

CE Hazardous Location Marking: **CE0539**

Ingress Protection: **IP55**

EFi150xx Approval

INMETRO Certificate #: **UL-BR 13.0593X**

EFi50xx Motor Approval Class I-II Group D, E, F, G

EFi50xx Motor Part Number 1131007404



Performance

| Airflow | EFi50xx | EFi120xx | EFi150xx |
|--|--------------------------------------|--------------------------------------|--------------------------------------|
| Free Air | 3,200 cfm (5,440 m ³ /hr) | 3,750 cfm (6,375 m ³ /hr) | 4,459 cfm (7,580 m ³ /hr) |
| Through Duct 15'/4.6 m w/ one 90° turn: | 1,935 cfm (3,289 m ³ /hr) | 2,700 cfm (4,590 m ³ /hr) | 3,179 cfm (5,404 m ³ /hr) |

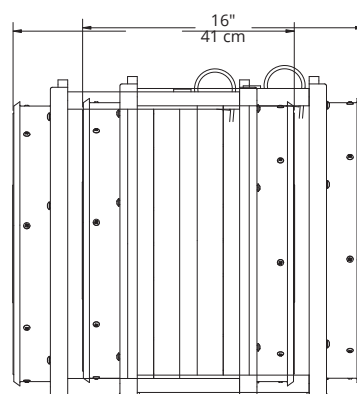
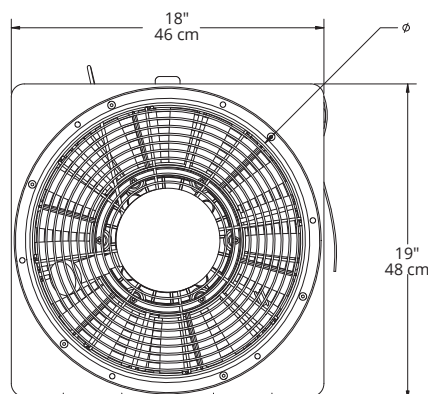

Available Accessory

ECKO Flex™ Anti-Static Duct with carrying bag

Order # FDT-1615CBR - 16" (40cm) anti-static duct
15' (4.6 m), w/ carrying bag

Order # FDT-1625CBR - 16" (40cm) anti-static duct
25' (7.6 m), w/ carrying bag



062617